



Strux SM™

SUPERIOR SOFT METAL CLINCH SOLUTION

Strux SM™ is our next generation of clinch product designed for soft metal, offering a stronger and more reliable assembly alternative to traditional clinch studs into the same material. Using an identical hole size and installation method to that of Strux®, Strux SM™ offers the ultimate performance in soft metal.

FEATURES

- ▶ New rib profile equally spaced around the head
 - Prevents rotation after being staked into sheet material
- ▶ Displacement Collar
 - Displaces sheet material into retaining groove
- ▶ Retaining Groove
- ▶ Retaining Ring
 - Barrier for displaced material to prevent pushout

BENEFITS

- ▶ Significantly higher push out and torsional resistance in aluminium vs. current competing clinch product
- ▶ Minimalized panel distortion from installation
- ▶ Fasteners may be installed close together with less panel distortion than current competing clinch product
- ▶ Consistent performance
- ▶ Simple tooling for manufacturing
- ▶ Fast and easy installation - can be installed in-die or using automated equipment
 - Low cost, long life installation tooling compared to competitors
- ▶ May be installed into difficult to weld materials
- ▶ Seals against fluids without the need for expensive chemical sealants
- ▶ Each thread size (M5-M12) has a single design for reduced product complexity

IDEAL APPLICATIONS

- ▶ Bumpers and Beams
- ▶ Heat Shield
- ▶ Battery Pack Enclosures
- ▶ Body and Closures
- ▶ Roof Rails



GEOMETRY AND DESIGN

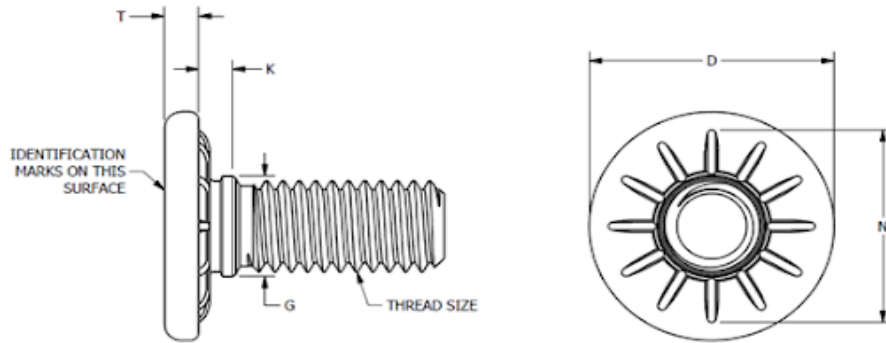

THREAD SIZE	DESIGN (MIN. MATERIAL THICKNESS) (mm)	D HEAD O.D. (mm)	T HEAD HEIGHT (mm)	G RETAINING RING O.D. (REF.) (mm)	K UNDERHEAD TO RETAINING RING DISTANCE (REF.) (mm)	N RIB O.D. (REF.) (mm)
M5	1.0	12.50 12.00	1.50 1.20	5.61	1.5	10.90
M6	1.0	14.25 13.75	1.80 1.50	6.61	1.5	12.40
M8	1.5	18.50 18.00	2.40 2.10	8.61	2.2	14.90
M10	2.3	23.00 22.50	2.90 2.60	10.61	2.9	17.90
M12	2.3	27.50 27.00	3.60 3.30	12.61	2.9	20.90

THREAD SIZE	DESIGN (MIN. MATERIAL THICKNESS) (mm)	APPROXIMATE PUSH OUT FORCE (N)	APPROXIMATE UNSUPPORTED TORSIONAL RESISTANCE FORCE (N'm)
M5	1.0	800	15
M6	1.0	900	20
M8	1.5	2,100	48
M10	2.3	3,800	107
M12	2.3	4,100	154

Performance approximations based on 5052-H32 Aluminium. Approximate unsupported torsional resistance values exceed the ISO 898-7 standard for minimum breaking torque, and therefore may result in stud fracture before the stated value is achieved.